

Description of Four Microphone Infrasonic Summing Amplifier

This infrasonic amplifier accepts the signal from up to four electret condenser microphones and sums them. It provides the correct microphone operating voltage and load resistance for microphones using the Panasonic WM-52BM electret cartridge. The summed signal passes through a variable gain amplifier. Differential Gains of between 6 and 48 dB can be selected in 6 dB steps by means of internal switches. The frequency response of the amplifier is 3 dB down at 0.1 Hz and 36 Hz. The differential output amplifier is capable of driving the capacitive loads presented by long cable runs. See the block diagram below.

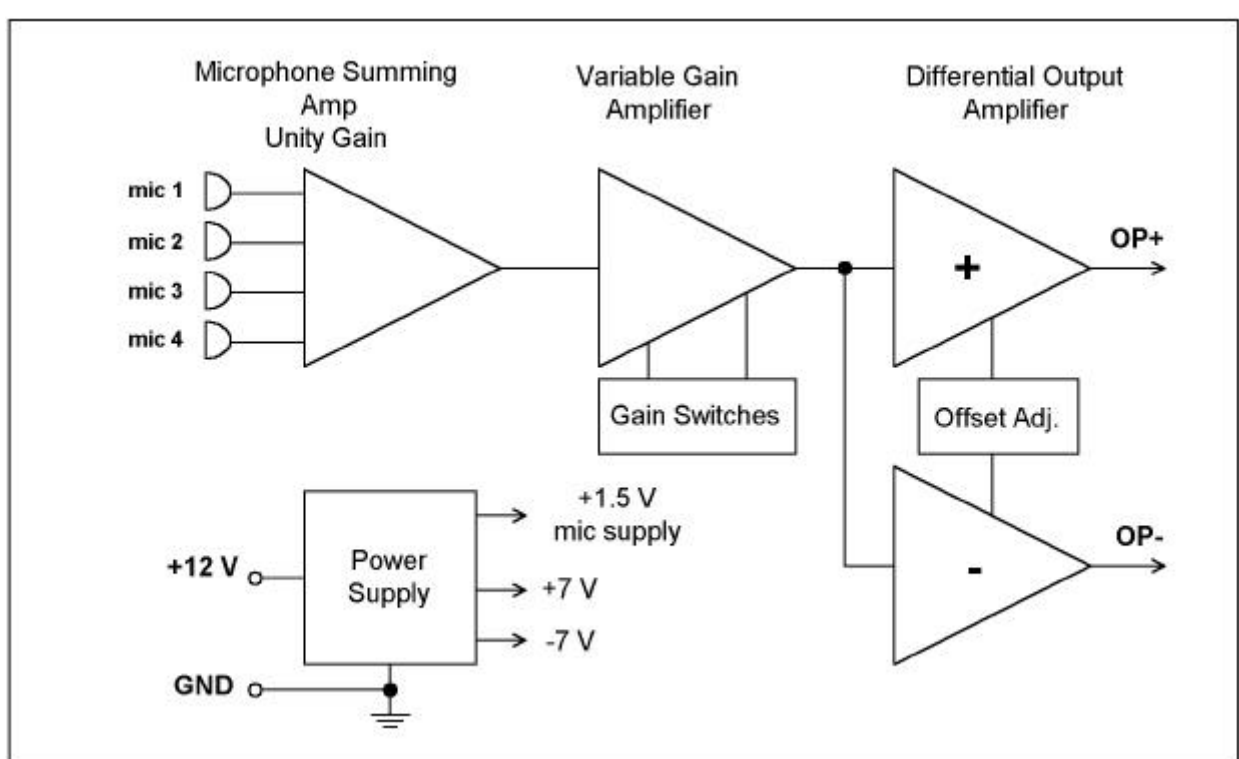

Block Diagram of Four Channel Microphone Amplifier

Internal Adjustments

There are two adjustments that can be made by opening the amplifier case. There is a trim-pot at one end of the printed circuit board which can be used to remove DC offset from the output amplifier. Set this adjustment in the same mode as the output connection. It is made with respect to ground for single-ended operation or differentially for differential operation. The second adjustment is gain and is set with the DIP switches located in the center of the printed circuit board.

The gain DIP switches are numbered from 1 to 8. The lowest numbered closed switch sets gain. Where n is the lowest switch, the gain is set by the following:

$$G_{dB} = 20 \log 2^n .$$

Microphone Response

Operation of the Panasonic WM-52BM electret microphone cartridge in the infrasonic band (below 20 Hz) is outside the manufacturer's specified range of operation. Because of this, the sensitivity and response of 25 units were tested in an attempt to characterize the response below 20 Hz. The test showed that the low end response of each unit was dominated by a single high pass pole. The frequency of the pole was between 1.1 and 4.8 Hz. Half the units had poles between 2 and 3 Hz.

Specifications

Amplifier Response: -3 dB at 0.1 Hz and 36 Hz

Amplifier Gain: switch selectable 6 to 48 dB differential, 0 to 42 dB single-ended.

Output Impedance: 300 Ω differential, 150 Ω single-ended.

Open-circuit Output Signal Swing: 12 volts peak differential, 6 volts peak single-ended.

Current Consumption at 12 volts: 8 mA quiescent, plus 3 mA per microphone.

In Band Microphone Sensitivity: -44 dB \pm 2 dB, 0 dB = 1 V / Pa, nominally 6.3 mv / Pa.

Connection Notes

- 1) The electret microphones ***must be connected with the correct polarity***. The mics with clear plastic cable (zip cord) have polarity marked with tinned copper strands on the negative side. The positive side has plain copper strands. The mics using black cable have their polarity marked by the color of the cable wires. Red is positive. Black is negative.
- 2) The output of the summing amplifier (OP-, OP+) is differential and should be connected to the Reftek differential channel inputs without grounding either side and with the correct polarity. If a single ended connection is desired either output may be used with respect to ground but the output level will be halved and the "OP-" signal is phase inverted. ***Never ground "OP-" or "OP+"***. Long cable runs between the Reftek and the summing amp are permitted.

Electret Microphone Summing Amplifier Connections

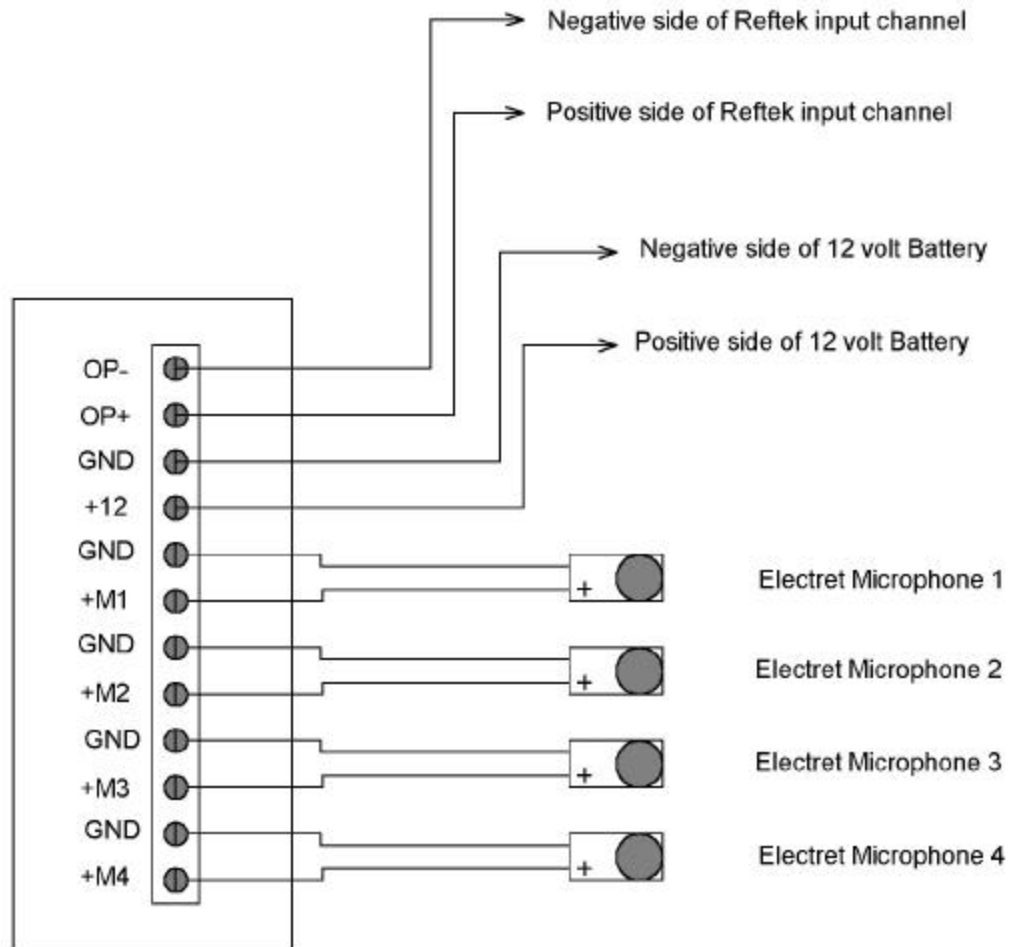

Connection Diagram

P. J. McChesney
patmc@pacifier.com

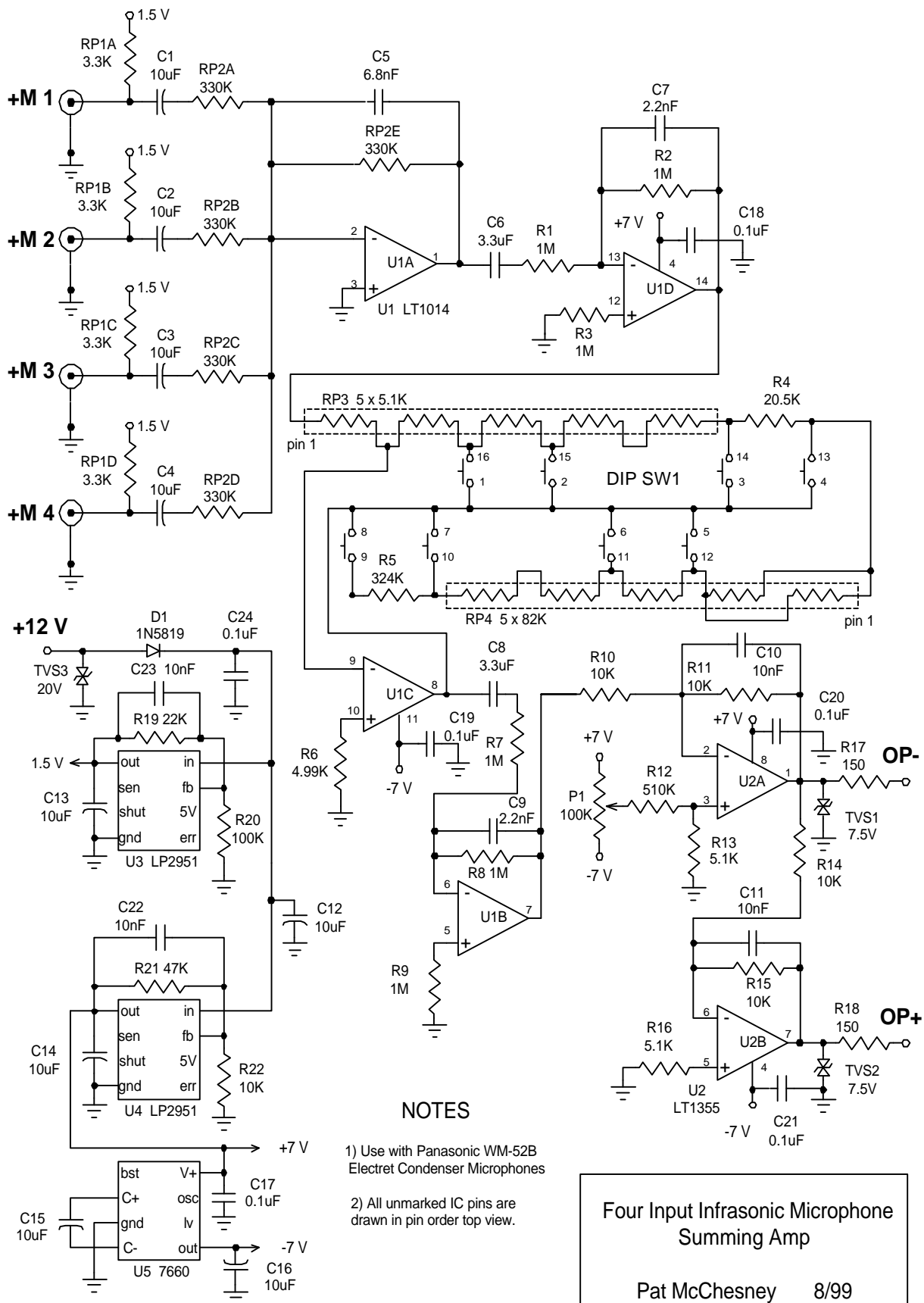

Four Input Infrasonic Microphone Summing Amp
 Pat McChesney 8/99